

Honeywell | Industrial & Commercial Thermal

**krom
schroder**

UV sensors UVS5, UVS10

Technical Information · GB

8 Edition 05.16I

- Virtually immune to interference due to its insensitivity to daylight, infrared radiation and incandescent bulbs
- Maximum safety thanks to protection against discontinuity or short-circuit on the flamesignal cable
- Suits industrial needs due to robust design
- Complies with the requirements of EN 298 in conjunction with Kromschöder automatic burner control units and burner control units



ERC **CE**



Table of contents

UV sensors UVS 5, UVS 10	1
Table of contents	2
1 Application	3
2 Certification	4
3 Function	5
3.1 Electrical connection	5
4 Replacement possibilities	6
Selection	7
5.1 Type code.....	7
6 Project planning information	8
6.1 Installation	8
6.2 Weak UV radiation	9
6.3 Electrical connection	9
7 Accessories	10
7.1 UVS 5.....	10
7.1.1 UV tube.....	10
7.2 UVS 10.....	10
721 UV tube	10
722 Adapter UVS 1	10
723 Cooling air adapter.....	10
724 Quartz glass disc.....	10
8 Technical data	11
8.1 UVS 5.....	11
8.2 UVS 10.....	12
9 Maintenance cycles	13
Feedback	14
Contact	14

1 Application

For monitoring gas burners of unlimited capacity with or without fan, on hot-air furnaces, gas-fired boilers, industrial furnaces and excess-gas flaring installations in conjunction with Kromschroder automatic burner control units and burner control units.

The UV sensors monitor the gas burners in intermittent operation.

The burners can either be ignited directly or operated as pilot and main burners.

UVS 5

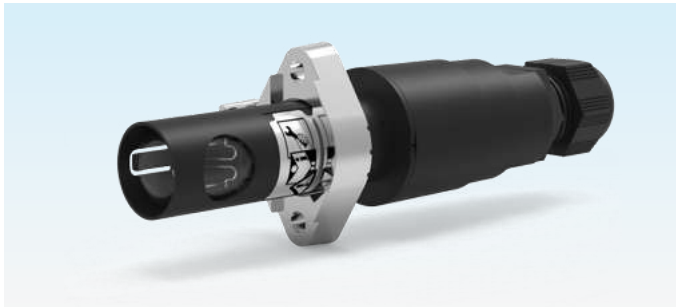

An old UVS 5 (with non-detachable PVC cable) can be replaced with the new UVS 5G1 (with cable gland and spring force terminals).

UVS 10

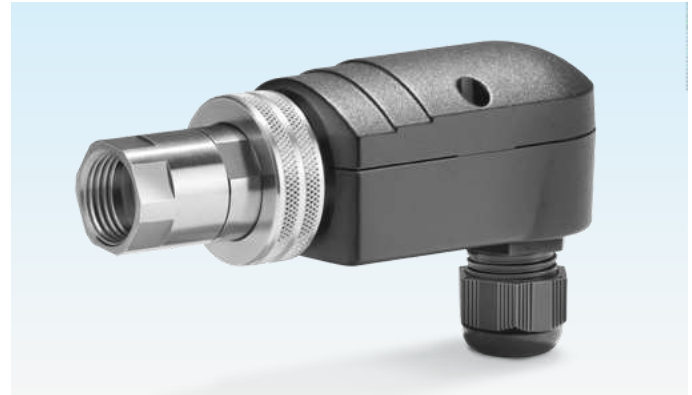

UV sensors UVS 1, UVS 6 and UVS 8 can be replaced by using various adapters with a heat guard made of quartz glass.



2 Certification



For certification, see Technical Information of the corresponding automatic burner control unit or burner control unit that the UV sensors UVS 5 or UVS 10 are to be used with.

Eurasian Customs Union



The products UVS 5 and UVS 10 meet the technical specifications of the Eurasian Customs Union.

3 Function

The UV tube detects the ultraviolet light of a flame. In the case of incident UV light, alternating current flows through the UV tube and is converted into a DC signal by the UV sensor. The DC signal can be processed by a flame signal amplifier.

The UV tube does not respond to daylight, incandescent bulb light or infrared radiation emitted by hot workpieces or red-hot furnace walls.

The designed lifetime of the UV tube is approximately 10,000 operating hours. For safety reasons, it must be replaced after this period.

UVS 10

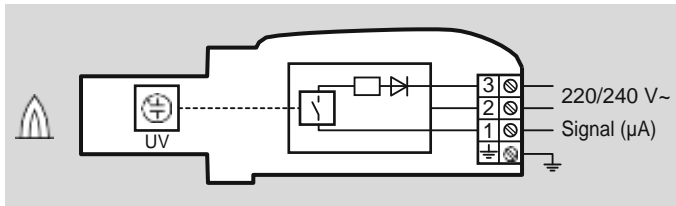

A quartz glass heat guard insulates the UV tube against the hot furnace atmosphere and protects against moisture, dirt and heat.

UVS 5

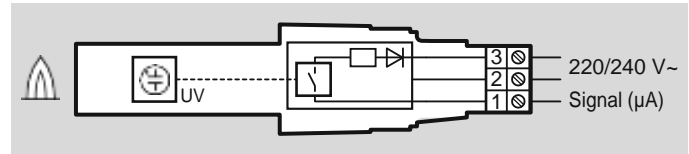

Protect the UV sensor against electrostatic charging by grounding the combustion chamber or the bracket.

3.1 Electrical connection

Example: electrical connection to automatic burner control unit IFD 258

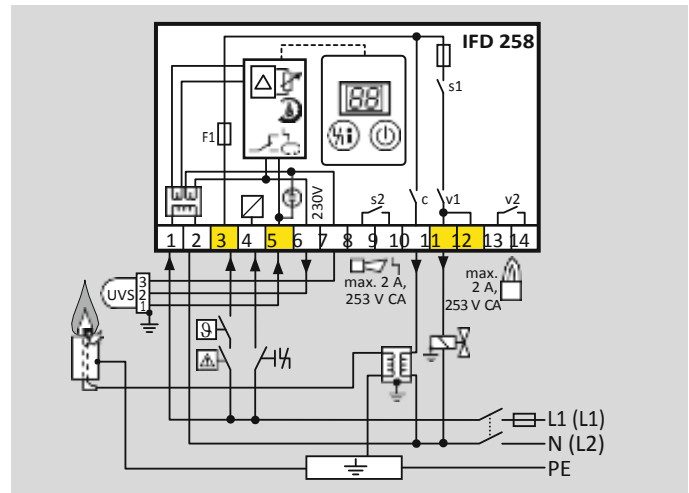

4 Replacement possibilities

UVS 1, UVS 6 and UVS 8 will be replaced by UVS 10D,

UVS 5 will be replaced by UVS 5G1

UV sensor		Note
Old	New	
UVS 1	UVS 10D0G1 ¹⁾	Replaces UVS 1 with heat guard ¹⁾ . UVS 1 connection cable can continue to be used.
UVS 5	UVS 5G1	Old bracket, clamping collar and PVC connection cable can continue to be used.
UVS 6	UVS 10D0G1	UVS 6 connection cable can continue to be used.
UVS 8	UVS 10D2	UVS 8 connection cable can continue to be used.

¹⁾ With Rp 1/2 internal thread

5 Selection

Type	G1*
UVS 5	
UVS 10D0	
UVS 10D1	
UVS 10D2	
UVS 10D3	
UVS 10D4	
UVS 10L0	
UVS 10L1	
UVS 10L2	
UVS 10L3	

* If "none", this specification is omitted.

= standard, = available

Order example

UVS 10LOG1

5.1 Type code

UVS 5

Code	Description
UVS	UV sensor
5	Series 5
G1	Electrical connection: M20 cable gland

UVS 10

Code	Description
UVS	UV sensor
10	Series 10
D	Quartz glass heat guard
L	Quartz glass heat guard lens
0	Rp1/2 internal thread
1	Rp 1/2 internal thread and cooling air connection
2	1/2 NPT internal thread
3	1/2 NPT internal thread and cooling air connection
4	UVS 1 adapter (28mm (1.1"))
G1	Electrical connection: M20 cable gland

6 Project planning information

6.1 Installation

The UV sensor may only be exposed to the UV light of its own flame. It should be protected from other sources of ultraviolet light. These could be, for example: neighbouring flames (this must be observed when monitoring pilot and main burners in particular), ignition sparks, arcs from welding devices or lamps emitting ultraviolet light.

Do not expose the UV sensor viewing opening to direct sunlight to avoid incorrect flame signals.

Direct the UV sensor at the flame inclined from above or in the horizontal so that no dirt collects in front of the UV sensor.

UVS 5

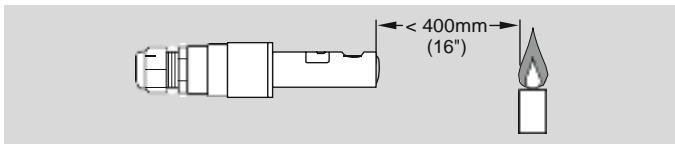

The sensor is mounted using the bracket supplied which is attached to the burner.

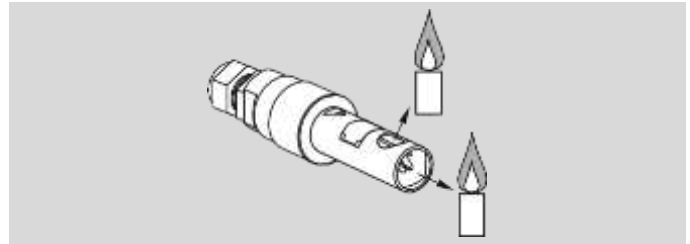

The UV tube can be directed towards the flame from the side or front with the help of the viewing openings in the sensor head.

UVS 10

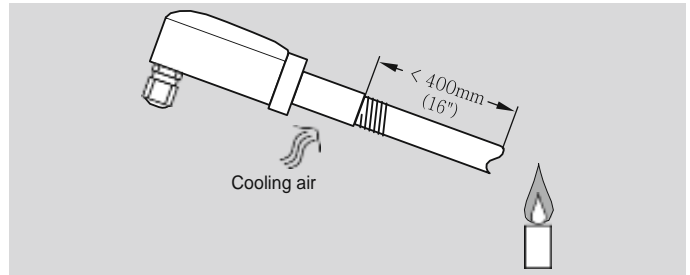

The sensor is mounted to a ½" viewing tube using the adapter (supplied) with integrated quartz glass heat guard. The viewing tube should be directed at the first flame third, as this is where the highest UV radiation is generally found. The inside of the steel tube should not be coated.

Supply cooling air to cool and protect the optical system from soiling and condensation.

6.2 Weak UV radiation

UVS 10

In order to concentrate weak UV radiation more effectively and to achieve a stronger UV signal, a quartz glass lens is available for the UVS 10, see page 10 (Quartz glass disc). When installing, ensure that the lens curvature points towards the flame. Thereby, the UV sensor must be precisely directed at the flame.

6.3 Electrical connection

The UV sensor is operated with an alternating voltage of 220/240 V. The voltage is provided by the automatic burner control unit or the flame detector.

Wire the UV sensor according to the connection diagram of the relevant automatic burner control unit or flame detector. A grounded mains is not required.

7 Accessories

7.1 UVS 5

7.1.1 UV tube

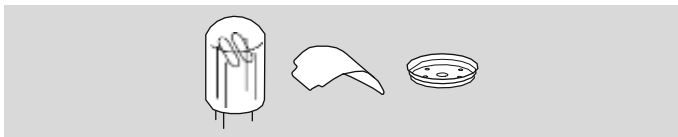

With sticker and seal

Order No.: 7 496 068 7

7.2 UVS 10

7.2.1 UV tube

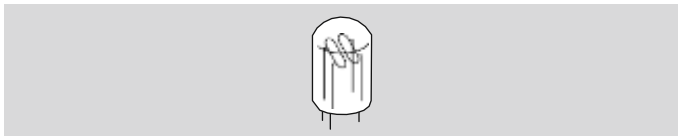

Order No.: 7 496 044 5

7.2.2 Adapter UVS 1

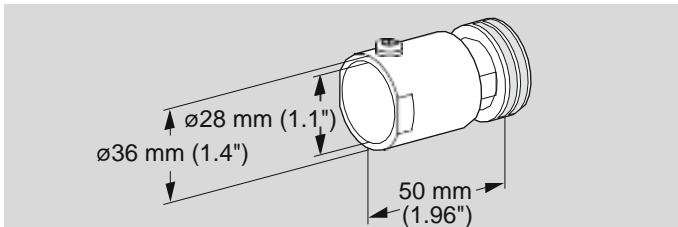

With quartz glass heat guard,

Order No.: 7 496 061 5

7.2.3 Cooling air adapter

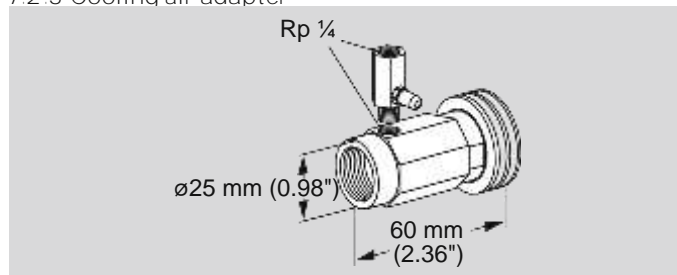

With quartz glass heat guard Rp

1/2, Order No.: 7 496 061 4

1/2 NPT, Order No.: 7 496 061 3

Nozzle for cooling air adapter, Order No.: 7 496 061 6

7.2.4 Quartz glass disc

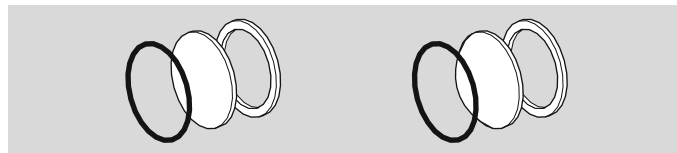

To protect the UV tube

Quartz glass disc with seal, Order

No.: 7 496 061 2

Quartz glass lens with seal

When installing, ensure that the lens curvature points towards the flame. Precisely align the UV sensor. The gap between the UV sensor and the flame can be increased to approximately 600 to 1200 mm (23" to 47").

Order No.: 7 496 061 1

8 Technical data

8.1 UVS 5

Plastic housing with connection terminals.

Wire cross-section for connection terminals:

≤ 1.5 mm² (≤ AWG 16).

Cable gland for cable diameters of 7 to 13 mm.

Distance between UV sensor and flame:

max. 400 mm (max. 16")

UV tube: P578,

spectral range: 190 – 270 nm,

max. sensitivity: 210 nm ± 10 nm.

Designed lifetime of the UV tube:

approx. 10,000 operating hours.

Min. DC signal: 1 µA.

Enclosure:

IP54 (Nema 3) in wiring chamber,

IP40 around the viewing openings with fitted tube and

seal.

Ambient temperature/storage temperature:

-40 to +80°C (-40 to +176°F).

Weight: 70 g (0.15 lbs).

Max. length of cable UV sensor – automatic burner control

unit:

see operating instructions for automatic burner control

unit.

Dimensions

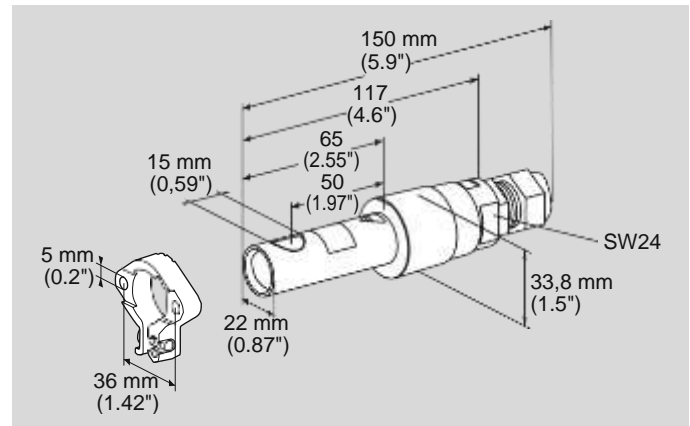

8.2 UVS 10

Aluminium housing with integrated heat guard,
with connection terminals.

Distance between UV sensor and flame:

300 – 400 mm (12 to 16"),

with quartz glass lens:

approx. 600 to 1200 mm (23 bis 47").

UV tube: P578,

spectral range: 190 – 270 nm,

max. sensitivity: 210 nm ± 10 nm.

Designed lifetime of the UV tube:

approx. 10,000 operating hours.

Min. DC signal: 1 µA.

Enclosure: IP 65.

Ambient temperature: -40 to +80°C (-40 to +176°F).

Weight: 280 g (0.6 lbs).

Max. length of cable UV sensor – automatic burner control unit:

see operating instructions for automatic burner control unit.

Dimensions

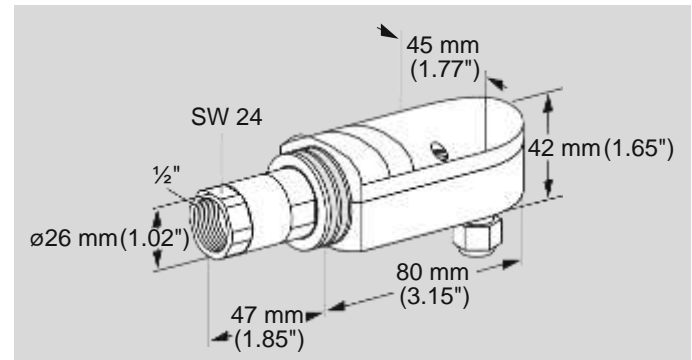

9 Maintenance cycles

Designed lifetime of the UV tube:

10,000 operating hours.

The UV tube must be replaced after this period, see page 10 (UVtube).

บริษัท เอดีดี เฟอร์เนส จำกัด

Add Furnace Co.,Ltd.

ที่อยู่:(bangkok): 44 ซ.บรมราชชนนี 70 ถ.บรมราชชนนี

ศาลาธรรมสพน์ ทวีวัฒนา กทม. 10170.

website: <https://www.addfurnace.com/>

e-mail: add028883472@gmail.com

โทร.(ออกแบบ): 08-08-170-170, 088-300-1122

โทร: 02-888-3472

Line ID: @add11 Wechat ID:

add0883001122

แฟกซ์:02-888-3258

The current addresses of our international agents are available on the Internet:
www.kromschroeder.de/Weltweit.20.0.html?&L=1

We reserve the right to make technical modifications in the interests of progress.
Copyright © 2016 Elster GmbH
All rights reserved.